

# Planning and Control of a Hybrid Vacuum-Forming System Based on Screw-pin Tooling

ZHIJIAN WANG, YAN WANG, NABIL GINDY

Department of Engineering  
University of Nottingham Ningbo  
China

[Zhijian.wang@nottingham.ac.uk](mailto:Zhijian.wang@nottingham.ac.uk) <http://www.nottingham.edu.cn/>

**Abstract:** - This paper introduced planning and control of a hybrid vacuum-forming machine system (HAVES). The HAVES was developed to integrate CAD/CAM, screw-pin tooling, CNC, vacuum forming and optical measurement device together to produce vacuum forming components. The screw-pin tooling was employed to replace traditional dedicated solid tooling and its reconfigurability provided the HAVES with advantages in rapid producing small batch and mass customization products. The whole control system of the HAVES is divided into two parts: one for screw-pin tooling adjustment and machining by using CNC control, and the other for vacuum forming by using PLC control. The detail design of the control system was discussed.

**Key-Words:** - Vacuum forming, Control system, Reconfigurable tooling, Screw-pin tooling, Hybrid, HAVES

## 1 Introduction

Vacuum forming process is a technique that is used to shape a variety of plastic sheet or composite parts. Traditional vacuum forming system uses dedicated tooling to produce components. Any design changes lead to the tooling being unsuitable for use, and a new one has to be made. This results in long lead time, high tooling cost and waste of material, especially for complex tooling.

Recently, there is a great deal of interest in developing reconfigurable pin tooling for forming thermoplastic and composite parts with compound curvatures (Walczyk, Hosford *et al.* [1]). Klesspies and Crawford [2] presented a method for producing large compound curved surfaces using a variable configuration vacuum forming mould. The mould is composed of a number of uniformly spaced round discrete pins, which are covered by a rubber interpolation sheet. A thermoplastic sheet is placed over the reconfigurable mould, heated using radiant heaters, and drawn into the mould surface using a drawing vacuum. A patent by Haas *et al.* [3] describes a modularized reconfigurable pin tool for the forming of composite honeycomb panels. The composite is heated or cooled by force air or inert gas through the modified hollow pins. An interpolating cloth is applied to evenly distribute the forced air over the composite surface and to suppress pin dimpling. Meilunas *et al.* [4] patented a reconfigurable tooling concept for forming laminated composite structures. The part shape and the desired ply stack are represented by CAD format in system design; the pre-impregnated composite materials are cut into

plies automatically and a ply feeder and stacker are used to stack the plies subsequently. The laminate is then transferred to the designed reconfigurable tool that equipped with double-diaphragm forming capabilities. Walczyk *et al.* [1] developed a computer-controlled, reconfigurable mould with square pins to sequentially form a compound curvature part shape from a flat composite lay-up, thereby facilitate composite shaping process automation. The reconfigurable mould is similar in structure to that of [2] except that the pins are square and close-packed. The hemispherical forming ends of the die elements are covered by an elastomeric interpolator to prevent dimpling of the composite lay-up. A vacuum pressure is applied to pull the top diaphragm, composite, and interpolator into contact with the mould surface in the process.

Although some research for reconfigurable tool have been done and small-scale reconfigurable tool prototypes have been built for vacuum forming application, surface quality of vacuum formed component based on reconfigurable tool still needs to be improved, a simple and cheap integrated vacuum forming system is also required. A hybrid vacuum-forming machine system (HAVES) was developed at The University of Nottingham to satisfy these requirements. The screw-pin tooling of the HAVES can be reconfigured and reused to produce many different components. This method overcomes the traditional lead time and cost issues associated with manufacturing components in low volumes; it has the potential to replace current dedicated moulds.

## 2 HAVES Planning

### 2.1 HAVES Requirements

The proposed HAVES test bed should possess the following four basic functions at the minimum: screw-pin adjustment, surface machining, vacuum forming and component evaluation.

#### 1. Screw-pin adjustment

As the shape of the SPT needs to be changed in response to different component geometry, the screw-pins can be adjusted in the axial direction. Rather than having a motor to simultaneously drive each individual pin to a pre-specified position, the screw-pin is rotated around its central axis to the required position one by one, and therefore only one tool is needed. To this end, a tool that is actuated by a servo motor to rotate screw-pins, thus moving them vertically is needed. The degree of freedom of the tool would be four axes: X, Y, Z and Z rotation (designated as C).

#### 2. Screw-pin tooling machining

After adjustment of the screw-pins, CNC machining can be prepared in order to eliminate most of the stairs that have been produced by discrete screw-pins and gain a relatively smooth mould surface. The machined screw-pin tooling surface may need further treatment before forming a vacuum because of the small gaps among the screw-pins. A milling cutter is needed for milling operations and the degree of freedom should be the four axes: X, Y, Z (designated as W in order to differentiate from the Z motion of screw-pin adjustment) and Z rotation (designated as B to differentiate from C). The axes and spindle requirement of the HAVES can be summarized as in table 1.

#### 3. Vacuum forming

The vacuum forming process is applied to produce plastic components over the developed SPT. This vacuum forming module includes a heater, a vacuum pump and a suit of parts for plastic sheet clamping and movement. The selection of the vacuum pump, the heater and its associated control system will be dependent on the size of the component to be produced.

#### 4. Component evaluation

A digital model scanned from the vacuum formed component is compared with its CAD design model to the quality control of the finished product. The difference between the produced plastic component and the design model is to be used in

further screw-pin tooling adjustment. A GOM ATOS II-400 digitizing system will be employed to evaluate the components while the system communicates with the HAVES test bed via the internet.

Table 1 Axes and spindle of the HAVES

Axis/ Spindle	Description
X axis	Axis for machine tool moves left/right
Y axis (Y1, Y2)	Axis for machine tool moves forward/backward
W axis	Vertical axis with router spindle, moves up/down
Z axis	Vertical axis with screw-pin adjustment, moves up/down
C axis	Rotary axis attached to Z axis saddle
B axis	Router spindle for milling 3D forms from Screw-pin tooling

### 2.2 HAVES Architecture

The Author [5] developed a frame for the reconfigurable screw-pin tooling system in 2008. A more comprehensive architecture as shown in Fig. 1 was developed for the HAVES based on this frame to facilitate plastic component manufacture.

The HAVES integrates CAD/CAM, reconfigurable tooling, CNC, vacuum forming and optical measurement device together to satisfy functional requirements. The reconfigurable SPT plays an important role in the architecture. In operation, the candidate part is imported into CAD/CAM/CAE environments, where the appropriate screw-pin height positions are calculated and transferred to the CNC; an adjustment tool and a milling tool driven by the CNC are used to reconfigure and mill the SPT separately. The finished SPT is applied to the vacuum forming system to produce thermoplastic parts before the thermoplastic part is scanned and compared with the design model for further quality improvement. In order for the screw-pin tooling to be reconfigurable for different component geometry with minimal human interference, it is important for the screw pins to be automatically adjusted to appropriate positions to represent different component geometry. A supporting software is required to enable reconfigurable tooling.

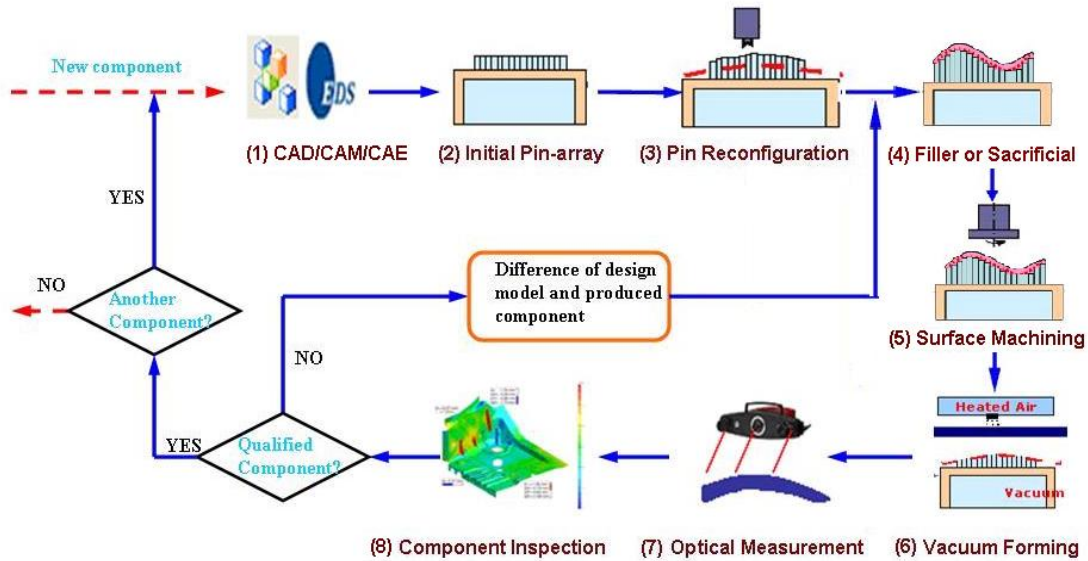

Fig.1 Development architecture of the HAVES test bed

### 3. HAVES Construction

To satisfy the HAVES test bed requirements proposed in section 2.1, a machine centre that integrates screw-pins adjustment and NC machining with vacuum forming machined is required. None of the standard NC machines has been integrated for vacuum forming operations thus making customisation of standard NC machines inevitable. Buying a standard new NC machine for customisation is considered vastly expensive for just a prototype, thus, a retrofit of an old machine would be a better option. A bridge (gantry) machine that is already available in the workshop is retrofitted for the HAVES design. In the following sections, the screw-pin tooling, vacuum forming system, dual tool head and constructed system of the HAVES will be introduced in detail.

#### 3.1 Screw-pin tooling

The screw-pin tooling as shown in Fig.2 is defined as a device that is composed of a group of identical screw pins arranged in an array pattern and a container which is formed by four engaged blocks [6]. Four lock bolts are used to clamp the four covers with the array pattern of the screw-pins. There is a gap between the side cover and front cover, which allows justification between screw-pin adjustment and screw-pin machining by adjusting the

screw-bolts. For easy screw-pin adjustment, the screw pin needs to be clamped relatively loosely, but still ensure that screw-pins are engaged properly, and in order to resist machining forces, the screw-pins have to be clamped firmly by the clamping bolts. Slide keys in Fig.2 (b) are used to ensure the relative position between the four covers and the screw-pin array pattern. A square datum block mounted on top of one container block is used as position reference for the screw-pin array pattern. The prototype of the screw pin tooling developed in this research is 19 rows and 20 columns with M20x300 screw-pins. In general, holes are drilled on the mould for vacuum pressure to be applied to the plastic component. For the screw-pin tooling, there are already holes between screw-pins, thus, there is no need for the drilling operation, which is considered to be an advantage of the screw pin tooling.

A customized adjustment tool is used to control the shape of the screw pin tooling. The diameter of the tool should be smaller than the diameter of screw to avoid interference between the adjustment tool and screw-pins. A small cone in the middle of the top end is used to locate the adjustment tool while the two blades near the cone are used to engage with the screw-pins and drive the screws to move.

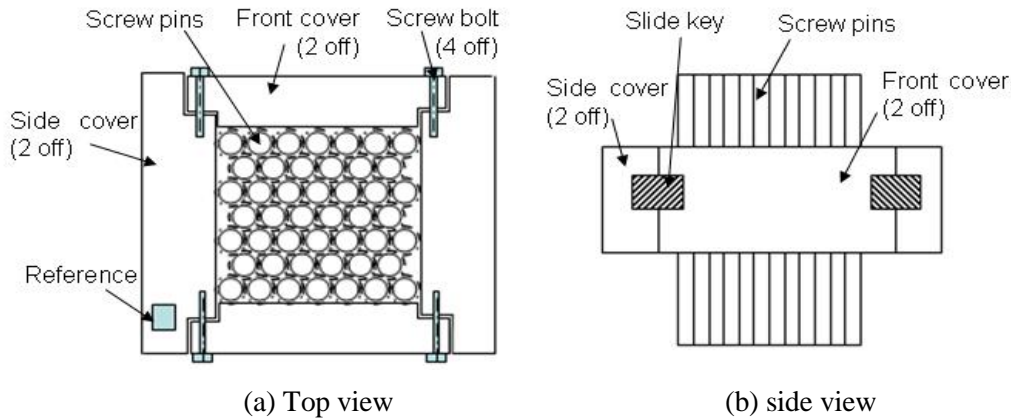

Fig.2 Design of screw-pin tooling

**3.2 Dual Head Tool**

It is not feasible to integrate the screw-pin tooling and the vacuum forming in the same position, as the heater may be in the way of the motion of the screw-pin adjustment and milling machining. As shown in Fig.3, the screw-pin batch is adjusted and machined at position (1) by the dual tool head and is moved to position (2) for component vacuum forming. Z axis saddle and W axis saddle are

assembled together and mounted on the two sides of the gantry beam. The screw-pin adjustment tool and the mill cutter have the same movement in the XY plane. In general, holes are drilled on the mould for vacuum pressure to be applied to the plastic component. For the screw-pin tooling, there are already holes between screw-pins, thus, there is no need for the drilling operation, which is considered to be an advantage of the SPT.

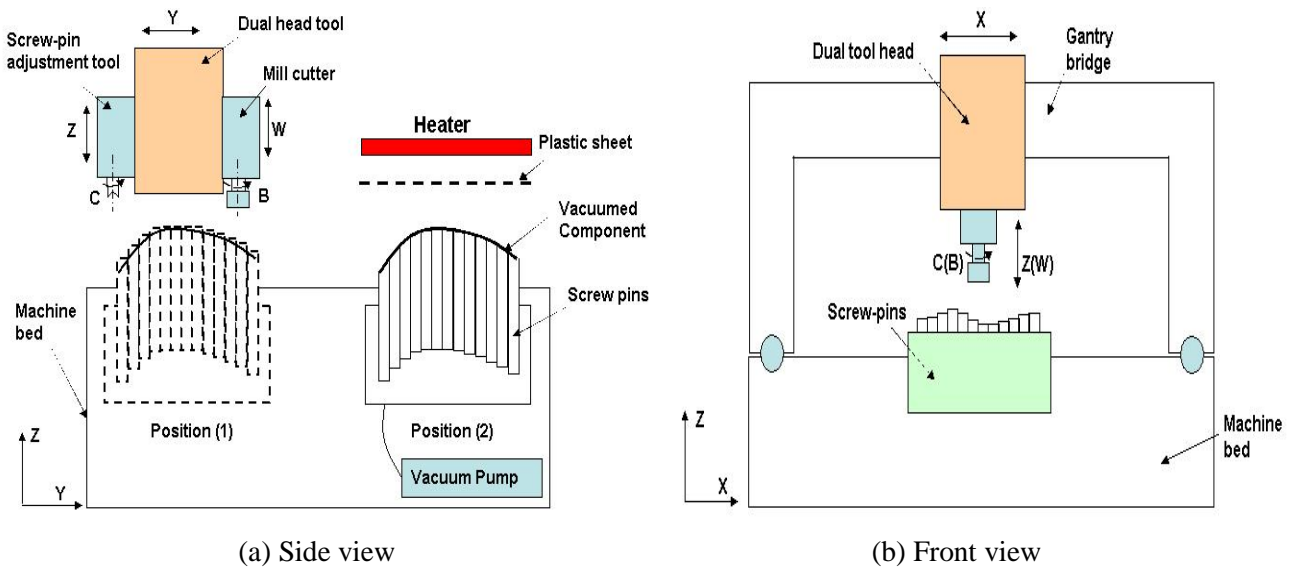

Fig. 3 Conceptual design of the dual tool head

**3.3 Vacuum Forming System**

Vacuum forming or thermoforming is a processing method in which a heated thermoplastic sheet is deformed and shaped over mould geometry by vacuum pressure [7]. The vacuum forming system of the HAVES is also shown in Fig.4, and its essential component includes:

- 1) A heater to heat plastic sheet to a specific temperature. The radiant heater P2424AX081, a standard part of RAYMAX 1120 part family from Watlow Company is selected as the system heater.
- 2) A vacuum pump to supply vacuum power for vacuum forming process. The model 1423-1010-G626X of GAST® rotary vane vacuum

pump is selected as part of the designed vacuum forming system.

3) A clamp and support frame to hold plastic sheet. The clamp frame needs to be sufficiently powerful to handle the thickest material likely to be formed on the machine, up to 6mm. The two frames are connected by spring latch.

4) Cylinders are used to lift up and down the plastic sheet for heating and forming. Two double acting, side port and flat end Norgren roundline cylinders RT/57232MF/500 are selected.

The working process of the proposed vacuum forming system is described as follows:

1) The plastic sheet is clamped between the clamp and the support frames;

2) The plastic sheet moves under the heater and the heater starts heating;

3) Once heated to forming temperature, the plastic sheet moves down driven by the cylinders to top of screw-pin tooling for moulding, and the heater is switched off at the same time;

4) The vacuum pump is started to evacuate air from vacuum box and help the plastic sheet drapes over the screw-pin tooling;

5) Once the vacuum gauge reaches proper vacuum, stop vacuum pump and cool the plastic sheet;

6) The formed plastic sheet is released from the screw pin tooling under the help of a reverse airflow and unclamped from the clamping frame.

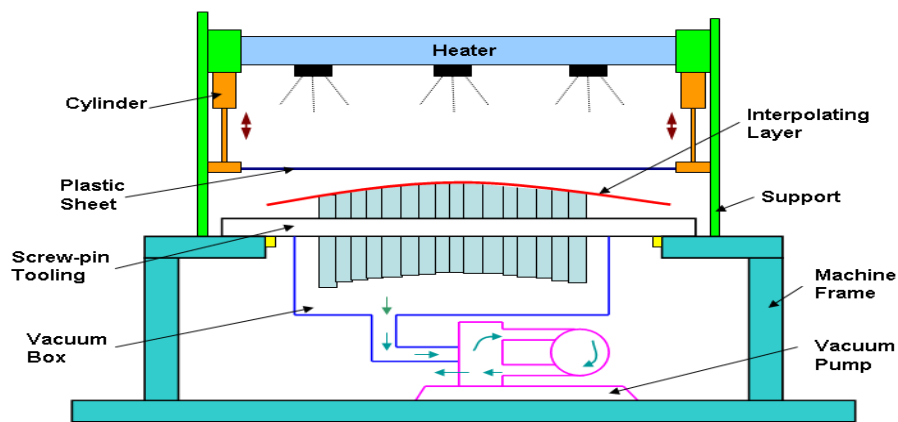

Fig. 4 Vacuum forming system of HAVES

**3.4 Constructed HAVES**

As shown in Fig.5, the HAVES is a machine centre that integrates screw-pin tooling, CNC and vacuum forming system together. The screw-pin batch is adjusted and machined by the dual tool head at the front of the support table and is moved to the rear of the support table for component vacuum forming. It is not feasible to integrate the screw-pin tooling and the vacuum forming in the same position,

as the heater may be in the way of the motion of the screw-pin adjustment and milling machining. Z axis (vertical adjustment of screw-pin tooling) saddle and W axis (vertical adjustment of milling cutter) saddle are assembled together and mounted on the two sides of the gantry beam. The screw-pin adjustment tool and the mill cutter have the same movement in the XY plane.



Fig.5 The completed HAVES



### 4 Control System Design

The control system is mainly used for receiving those control commands sent out by software. It drives corresponding dynamo servo driver or hydrometric drivers to realize the adjusting and positioning of actuating mechanism, and uses GUI mode to realize the control of position measuring and target motion [8].

To reduce system complex, the whole control system is divided into two units: one control unit for control screw-pin tooling using CNC and the other control unit for control vacuum forming system using PLC controller. Since hierarchical structure is one of the basic features of complex control systems [9], each control unit was designed in hierarchical structure independently from the other and they are described in the following sections respectively.

#### 4.1 Control unit for screw-pin tooling

Based on the analysis of system functional requirement and machine frame selection, the HAVES is required to control and manage 6 axes and one spindle shown in table 1. The drive and feedback measurement method for each axis are summarized and listed in table 2.

The machine movements are controlled by Fagor 8055 CNC which is composed of a central unit module, a monitor module and a keyboard module. The central unit further includes a CPU module, an axis module and I/Os modules, etc. As shown in Fig.6, the Fagor 8055 CNC is required to control 6 axes (X, Y1, Y2, Z, W, and C) and one spindle. Each axis includes several elements that should be managed by the CNC and they are detailed as follows:

Table 2 Drives and feedback measurement methods for axes

Axis	Drive	Feedback measurement
X axis	SEM MT30R4-58	Sony linear magnescale SL110
Y axis (Y1, Y2)	SEM MT30R4-58	Sony linear magnescale SL130
Z axis	SEM MT22R2-24	Hengstler RS58-O/1024AS.41RB
C axis	ECL S644-3B/T	Hengstler RS58-O/1024AS.41RB
W axis	SEM MT22D2-19	Heidenhain Rod TTL encoder

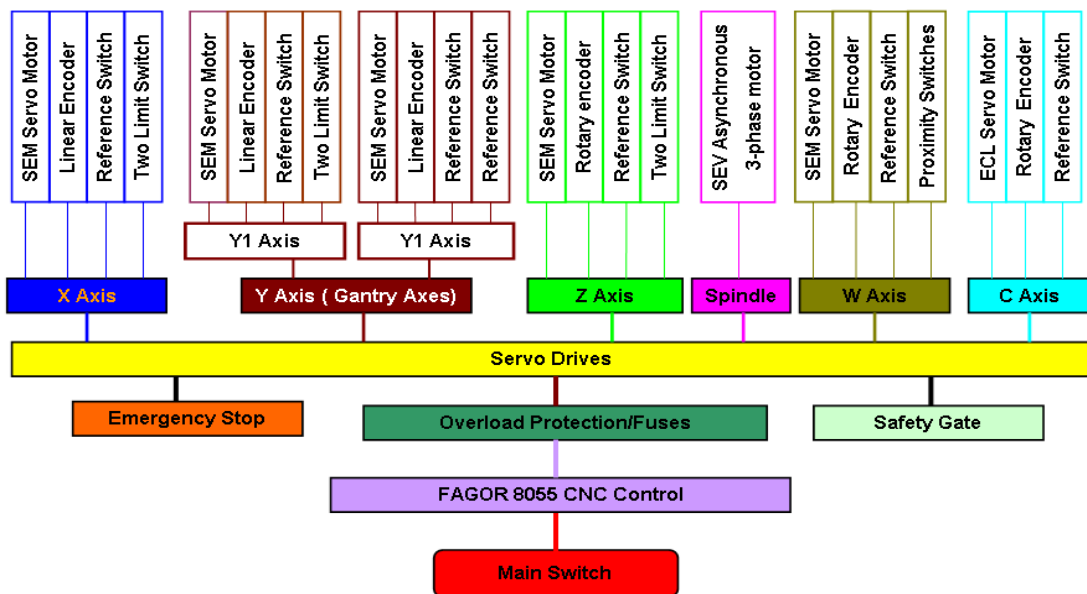

Fig.6 CNC (for axes and spindles) control diagram in the HAVES

- 1) X axis: one SEM ferrite brushed DC servo motor (model no. MT30R4-58), one Sony linear encoder, one reference switch and two limit switches;
- 2) Y axis: Y axis is a gantry axis and includes Y1 and Y2 two axes. The Y1 axis is called the main axis and its "Gantry" parameter set to "0"; the Y2 axis is called the slave axis and its "Gantry" parameter set "Y1 axis" as its "master". The Y1 axis and the Y2 axis must move together in synchronism, the parameter "MAXCOUPE" of the Y2 axis should indicate the maximum allowed difference between the following errors of both axes. Only the movement of the Y1 axis needs to be programmed. The Y1 axis and the Y2 axis have the same control elements which include one SEM ferrite brushed DC servo motor (model no. MT30R4-58), one Sony linear encoder, one reference switch and two limit switches;
- 3) Z axis: one SEM ferrite brushed DC servo motor (Model no. MT22R2-24), one Hengstler rotary encoder (one reference switch and two proximity switches);
- 4) C axis: one ECL DC permanent magnet servo motor (model no.S644-3B/T), one Hengstler rotary encoder and one reference switch;
- 5) W axis: one SEM ferrite brushed DC servo motor (model no. MT22D2-19), one Heidenhain rotary encoder, one reference switch and two limit switches.

Besides controlling the spindle and the axes of the machine, the Fagor CNC also governs an emergency stop, a safety gate and overload protection.

#### 4.2 Support software for screw-pin tooling

The purpose of the support software is to enable screw-pin adjustment to represent the different component geometry with minimal human interference. As shown in Fig.7, the support software

system includes three models: component discretization, screw pin tooling construction, adjustment and G code generation (SCAG), and screw-pin tooling display and verification (SPT-Demo).

##### 1 Component discretization

In order to obtain the component position information in response to the screw-pin array pattern, it is essential to discretize the 3D component surfaces. There are two types of discretization: discretization of a 3D CAD model and discretization of a 3D physical model. The discretization of a 3D CAD model is also called mesh generation, which is the same to that of Finite Element Analysis, therefore it is conducted within FEA software (ABAQUS/CAE). Discretization of a 3D physical model, employed when CAD models are not available, is conducted through scanning using GOM scanner.

##### 2 Screw-pin tooling construction, adjustment, evaluation and G code generation (SCAG)

SCAG is developed within a visual basic environment. The purpose is to read the generated file from the component discretisation process, construct or retrieve a screw-pin array pattern, calculate the amount of adjustment of the screw-pin, generate G code, and output the screw-pin array pattern.

##### 3 Display and verification

A customised menu on the CAD software (Unigraphics) using GRIP is developed to read the screw pin array pattern file and generate 3D solid screw-pin tooling, and the difference between component geometry and the screw-pins can be seen from the CAD software easily.

The software framework is shown in Fig. 8.

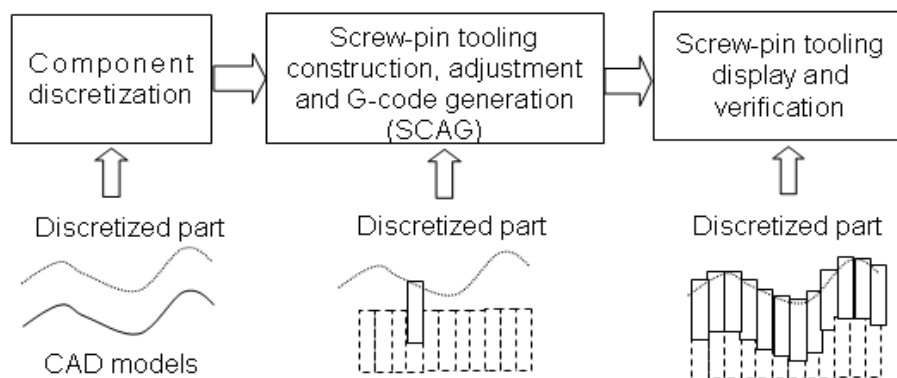

Fig.7 Procedures of digital tooling generation

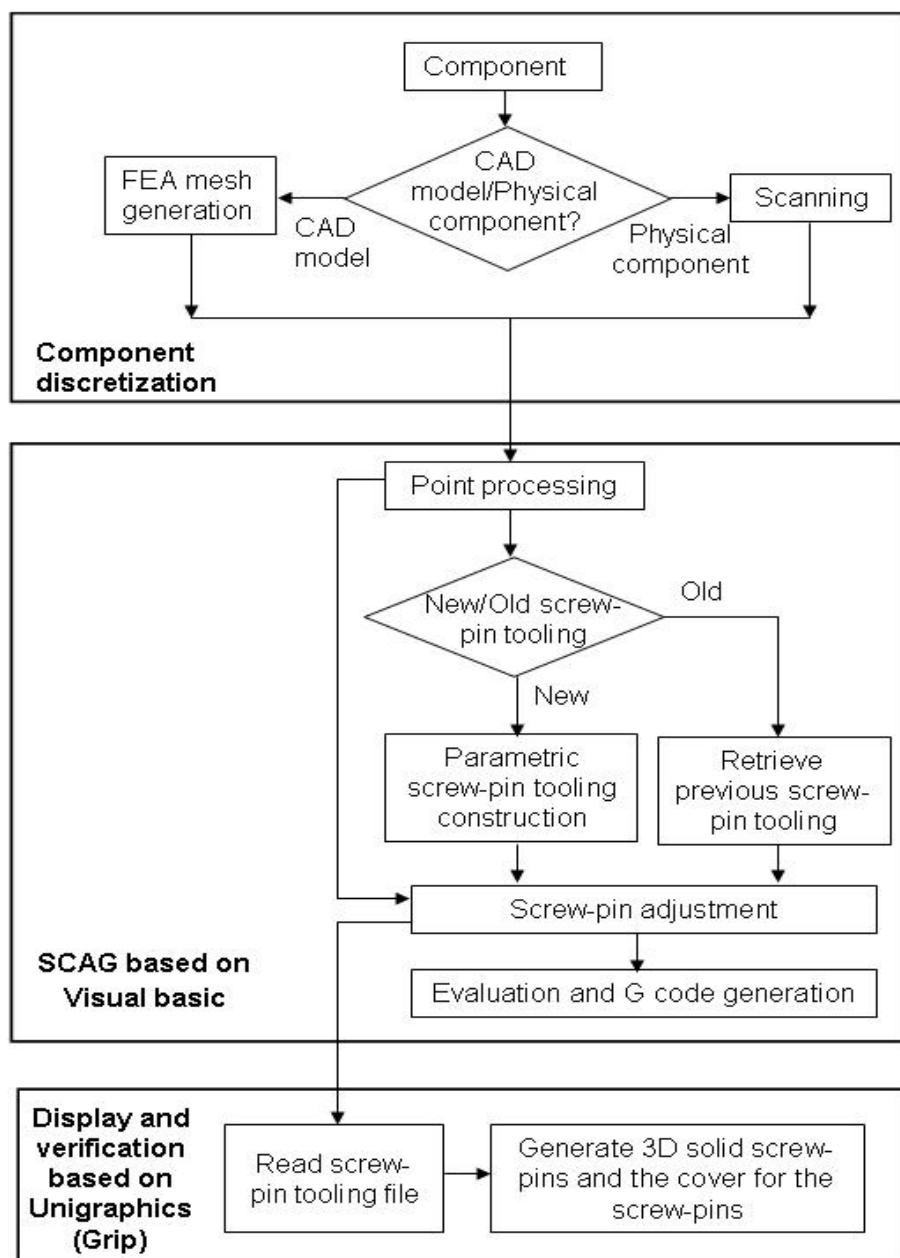

Fig.8 Software framework

### 4.3 Control unit for vacuum forming system

A programmable logic controller (PLC) or programmable controller is selected in order to control the heater, pump and positioning of the plastic sheet. The PLC is microprocessor-based systems, and is used in process-control applications [10]. The PLC is a standard unit with no dedicated application. The unit has to be connected to the various process input and output devices [11]. The purpose of the heater control is to set correct temperature and heating time on the heater to ensure that the plastic sheet is in the state ready for vacuum forming. It is conducted by using a thermo coupling

sensor and displacement sensor and closed loop control system. The thermo coupling sensor is used to measure the temperature on the surface of plastic sheet. The displacement sensor is employed to control the material sag of the plastic sheet. The closed loop control system will switch on and off the heater to maintain the heating temperature.

When a plastic sheet is heated the material will start to melt and the sheet will adopt an arc shape. The amount of the arc is an indication of the readiness of the material for the vacuum forming. Therefore the displacement sensor is used to measure the amount of drop the material has. Once the



material drop achieves the pre-assigned value, the sensor will send a signal to the controller, the cylinders will start to move the plastic sheet down, and the pump will be turned on for the vacuum forming process.

Fig.9 shows the control configuration of the vacuum system. A Watlow 1120 radiant heater is connected to the system via a DIA-A-MITE solid-state power controller. A Watlow PID controller 1/16 DIN driven by 240V power is used to remote control the heater temperature and the displacement sensor. The heater temperature is monitored by a thermocouple mounted under the heater. A DIN Rail Mounting Component Box System is applied to integrate the GAST rotary vane vacuum pump into the system. A PLC controller driven by 24V power is assembled with the control panel to connect/disconnect power, turn on/off the heater, switch on/off vacuum pump, set manual/auto operation method, and also it works together with two-way compact solenoid valves and pneumatic valve to control the movement of Norgren roundline cylinder.

As part of the control system, the control panel as shown in Fig.9 helps users to remotely control heater, vacuum pump and cylinders. There are five buttons, one heater light and one temperature

controller in the control panel and each button has two working conditions:

- 1) Cylinder button: 0 cylinder up, 1 cylinder down;
- 2) Vacuum pump button: 0 vacuum forming off, 1 vacuum forming on;
- 3) Heater button: 0 heater off, 1 heater on;
- 4) Start button: 0 starts off, 1 start on;
- 5) Operation button: 0 manual control, 1 auto control.

## 5 Conclusion

The HAVES integrates screw-pin tooling, CNC and vacuum forming together to manufacture products in a rapid and cost-effective way. The control system for the HAVES is made up of two parts: one part is CNC control for screw-pin tooling adjustment and machining; the other part is PLC control for vacuum forming process. This paper proposed control system design for both of the two parts. The Fagor 8055 CNC is employed to control movement of 6 axes (X, Y1, Y2, Z, W, and C) and one spindle and the PLC controller is used to control heater temperature, vacuum pump on/off and cylinder movement accordingly. Further system calibration and experiments are required for implementation the constructed HAVES test bed.

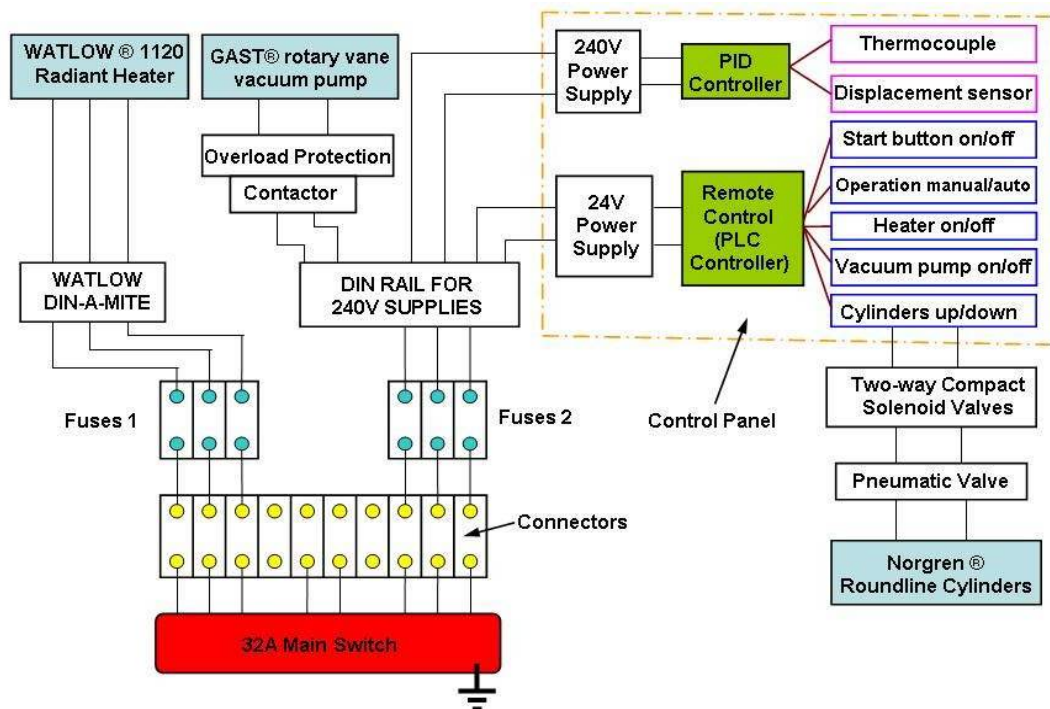

Fig.9 Control diagram for vacuum forming system in the HAVES

*References:*

- [1] Walczyk, D.F., Hosford, J., and Papazian, J.M., Using Reconfigurable Tooling and Surface Heating for Incremental Forming of Composite Aircraft Parts, *ASME Journal of Manufacturing Science and Engineering*, Vol. 125, No. 2, 2003, pp. 333–343.
- [2] Kleespies, H.S. III and Crawford, R.H., Vacuum forming of compound curved surfaces with a variable geometry mould, *Journal of Manufacturing Systems*, v 17, n 5, 1998, pp. 325-337.
- [3] Haas, E.G., Schwarz, R.C. and Papazian, J.M., Modularized, Reconfigurable Heated Forming Tool, *U.S. Patent No. 6089061*, issued July 18 2000.
- [4] Meilunas, R.J., Dillon, G.P., and Nardiello, J.A., 2002, System for Constructing a Laminate, *U.S. Patent No. 6,484,776*, issued November 26.
- [5] Wang, Z.J., Wang, Y. and Gindy, N., Design and Construction of Reconfigurable Screw-Pin Tooling for Vacuum Forming System, *Proceeding of The 18th International Conference on Flexible Automation and Intelligent Manufacturing (FAIM 2008)*, 29th June to 2nd July, Sweden, 2008
- [6] Wang, Y., Wang, Z.J. and Gindy, N., Experimental design and investigation of a screw-pin tooling system for vacuum forming components, *Proceedings of the 5th International Conference on Responsive Manufacturing (ICRM 2010)*, 11-13 January 2010, pp. 75-83.
- [7] Lee, J.K., Virkler, T.L. and Scott, C.E., Influence of initial sheet temperature on ABS thermoforming, *Polymer engineering and science*, Vol. 41, No.10, 2001, pp. 1830-1844.
- [8] Zou, J.H., Riaz, A. and Fan, Y.Q., Research for Major-Parts Digital Assembly System of Large-Scale Airplane, *Proceedings of the 5th WSEAS Int. Conf. on CIRCUITS, SYSTEMS, ELECTRONICS, CONTROL & SIGNAL PROCESSING*, Dallas, USA, November 1-3, 2006, pp.337-343.
- [9] Bagdasaryan, A.G., System Approach to Synthesis, Modeling and Control of Complex Dynamical Systems, *WSEAS TRANSACTIONS on SYSTEMS and CONTROL*, Issue 2, Volume 4, February 2009, pp. 77-87.
- [10] Zeqiri, N. and Luma, A., Control systems, smart sensors, controller, elements in a control loop, Java Card and Security, *WSEAS TRANSACTIONS on SYSTEMS and CONTROL*, Issue 5, Volume 3, May 2008, pp. 365-374.
- [11] Fagarasan, I., Iliescu, S.St., Dumitru, I., Arghira, N. and Bucur, I., Modular System for Process Control Testing, *WSEAS TRANSACTIONS on SYSTEMS and CONTROL*, Issue 7, Volume 4, July 2009, pp.329-338.